

The information in this document is subject to change without notice and should not be construed as a commitment by ABB. ABB assumes no responsibility for any errors that may appear in this document.

Except as may be expressly stated anywhere in this document, nothing herein shall be construed as any kind of guarantee or warranty by ABB for losses, damages to persons or property, fitness for a specific purpose or the like.

In no event shall ABB be liable for incidental or consequential damages arising from use of this document.

This document and parts thereof must not be reproduced or copied without ABB's written permission, and contents thereof must not be imparted to a third party nor be used for any unauthorized purpose. Contravention will be prosecuted.

Additional copies of this document may be obtained from ABB at its then current charge.

© Copyright 2015 ABB ALL right reserved.

ABB AB

SE-721 68 Västerås
Sweden

We reserve all rights in this document and in the information contained therein. Reproduction, use or disclosure to third parties without express authority is strictly forbidden. © Copyright 2003 ABB

Latest revision: ECO 77348, WI 109538 Page 10: Wire no 3 added.		 Lab/Office: DMRO SE PRIM	IRB 6620 COPYRIGHT page	Status: 2016-01-14 APPROVED Document no. 3HAC025090-001	Plant: = IRB6620 Location: + Manipulator Sublocation: + Rev. Ind 04 Page 1 Next 2 Total 14
Prepared by, date: EM 151217	Approved by, date: JM 160114				

Valid for:
 This circuit diagram is valid for the following cable harness assemblies:
 3HAC025054-001 Manipulator harness axis 1-6
 3HAC033434-001 Manipulator harness axis 1-6 LX
 3HAC15930-1 UL signal lamp
 3HAC15619-1 Cable FB7-SMB1.7

We reserve all rights in this document and in the information contained therein. Reproduction, use or disclosure to third parties without express authority is strictly forbidden. © Copyright 2003 ABB

Latest revision: ECO 77348, WI 109538 Page 10: Wire no 3 added.		 Lab/Office: DMRO SE PRIM	IRB 6620 Valid For	Status: 2016-01-14 APPROVED Document no. 3HAC025090-001	Plant: = IRB6620 Location: + Manipulator Sublocation: + Rev. Ind 04 Page 3 Next 4 Total 14
Prepared by, date: EM 151217	Approved by, date: JM 160114				

We reserve all rights in this document and in the information contained therein. Reproduction, use or disclosure to third parties without express authority is strictly forbidden. © Copyright 2003 ABB

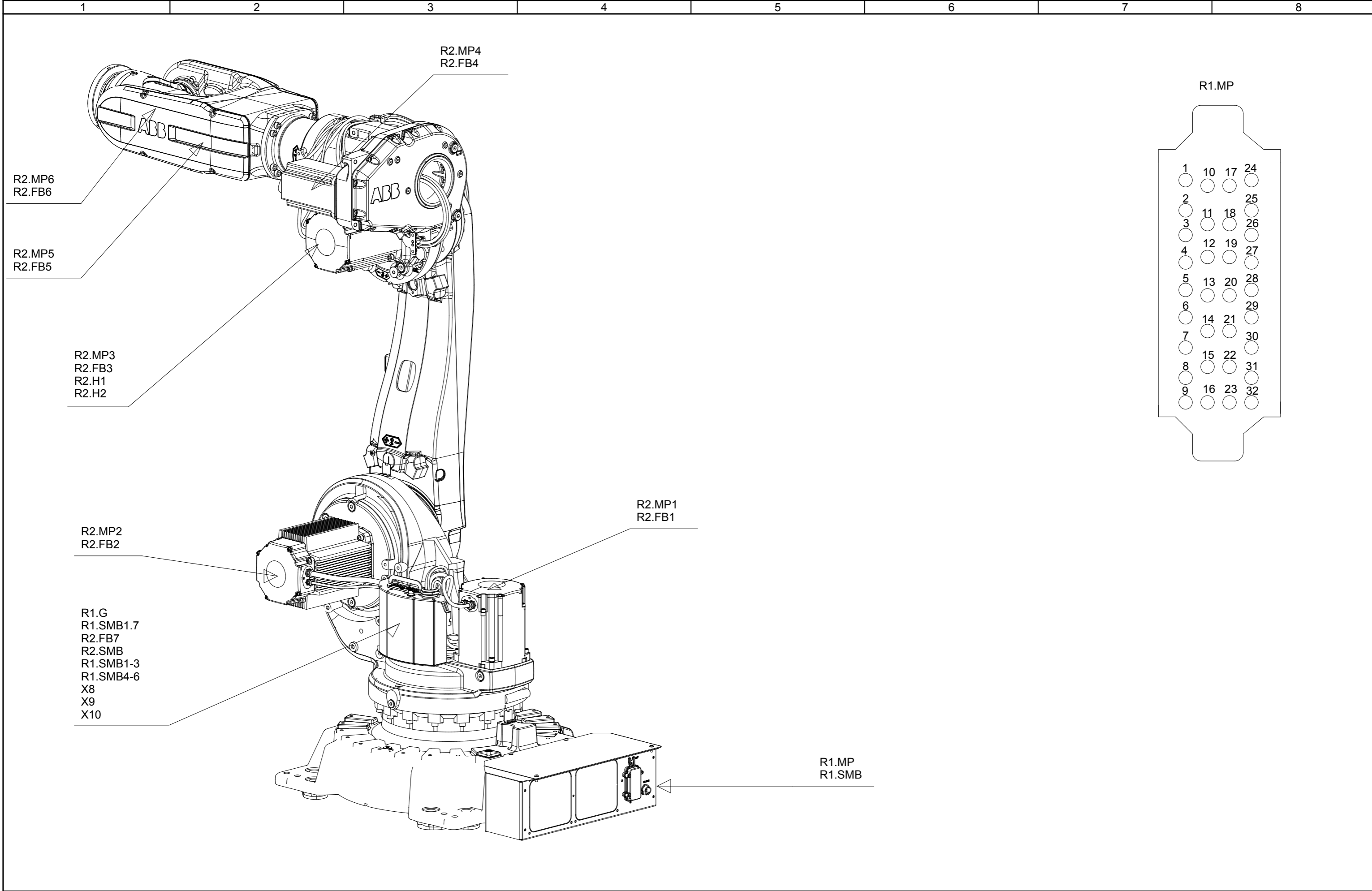

Latest revision: ECO 77348, WI 109538
Page 10: Wire no 3 added.

Prepared by, date: EM 151217 Approved by, date: JM 160114



Lab/Office:
DMRO SE
PRIM

IRB 6620

Connection point location

Status: 2016-01-14

Plant: = IRB6620

Location: + Manipulator

Sublocation: +

APPROVED

Document no. 3HAC025090-001

Rev. Ind **04**

Page 4
Next 5
Total 14

M	Motor		Protective Earth
R	Resolver		
G	Battery Pack		Twisted wires
BU	Brake Release Unit		
FB	Feedback unit		Screened wires
SMB	Serial Measurement Board		
Keypin	Location pin to avoid mismatch		

We reserve all rights in this document and in the information contained therein. Reproduction, use or disclosure to third parties without express authority is strictly forbidden. © Copyright 2003 ABB

We reserve all rights in this document and in the information contained therein. Reproduction, use or disclosure to third parties without express authority is strictly forbidden. © Copyright 2003 ABB

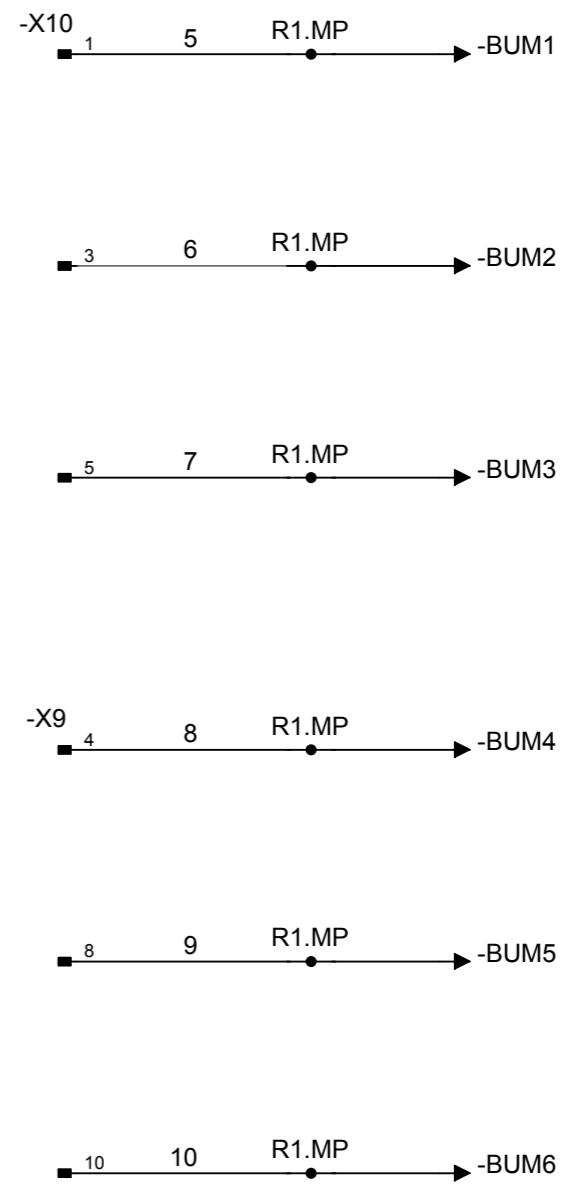
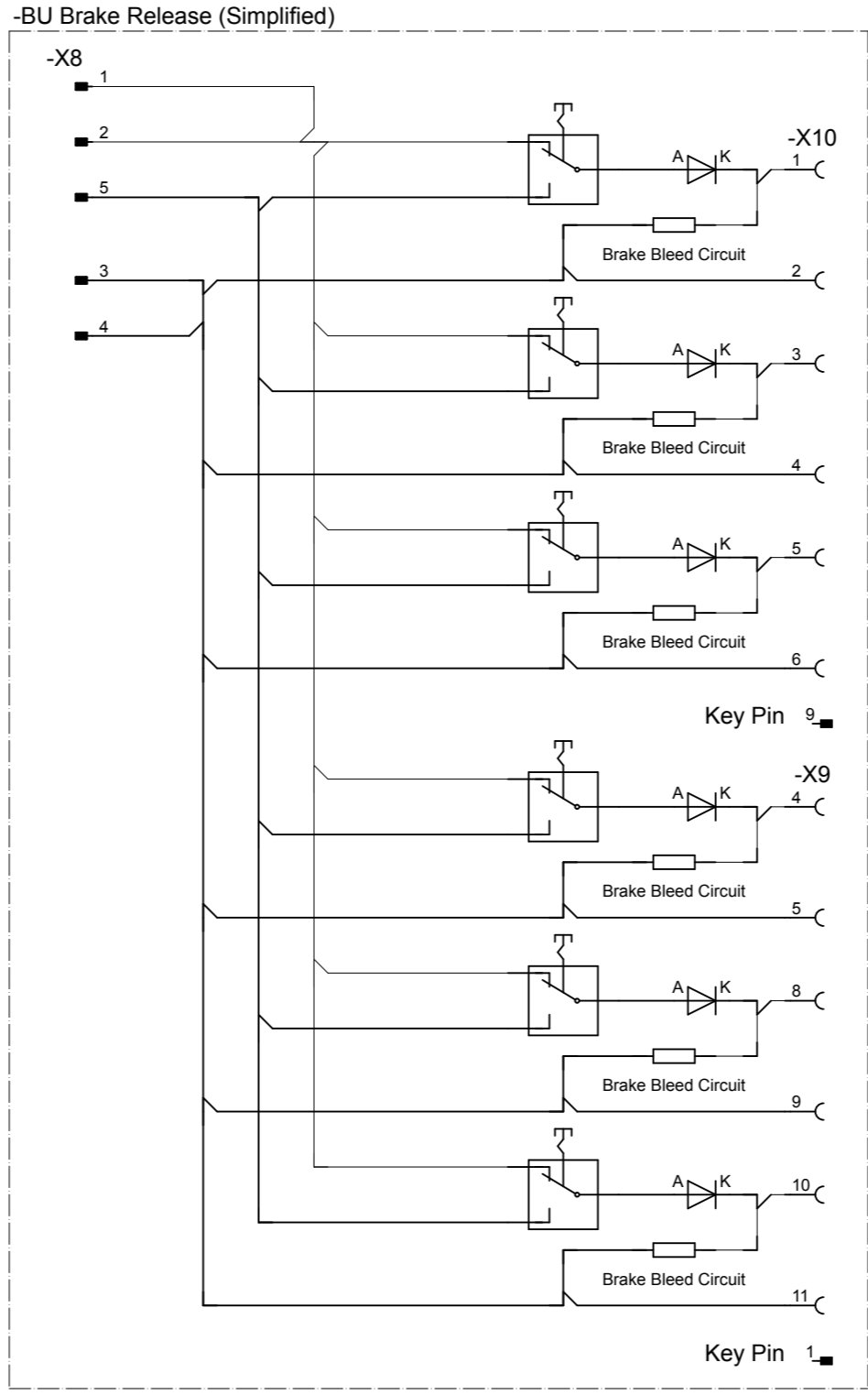
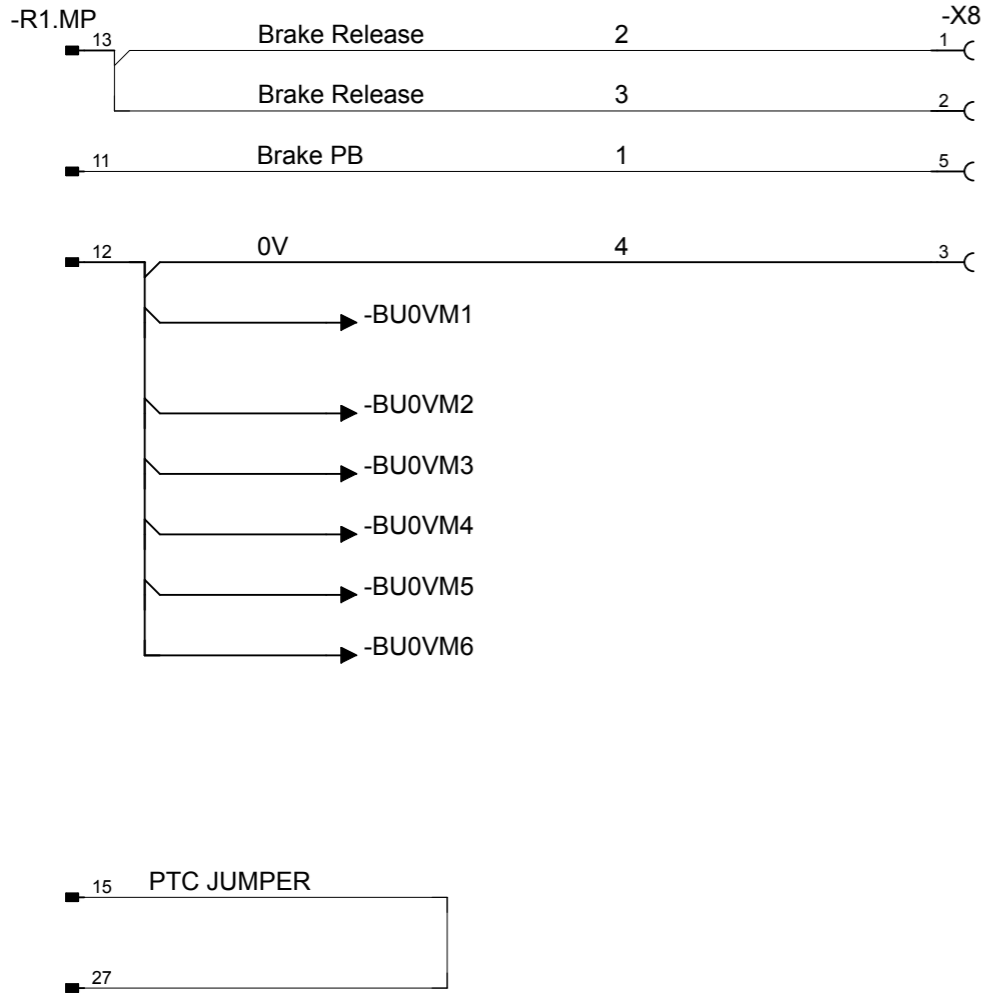

Latest revision: ECO 77348, WI 109538
Page 10: Wire no 3 added.

Prepared by, date: EM 151217 Approved by, date: JM 160114



Lab/Office:
DMRO SE
PRIM

IRB 6620
Brake Release Unit

Status: 2016-01-14

APPROVED

Document no.
3HAC025090-001

Plant: = IRB6620
Location: + BU
Sublocation: +

Rev. Ind	Page 10
04	Next +SMB/2
	Total 14

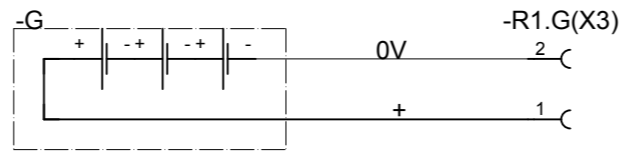
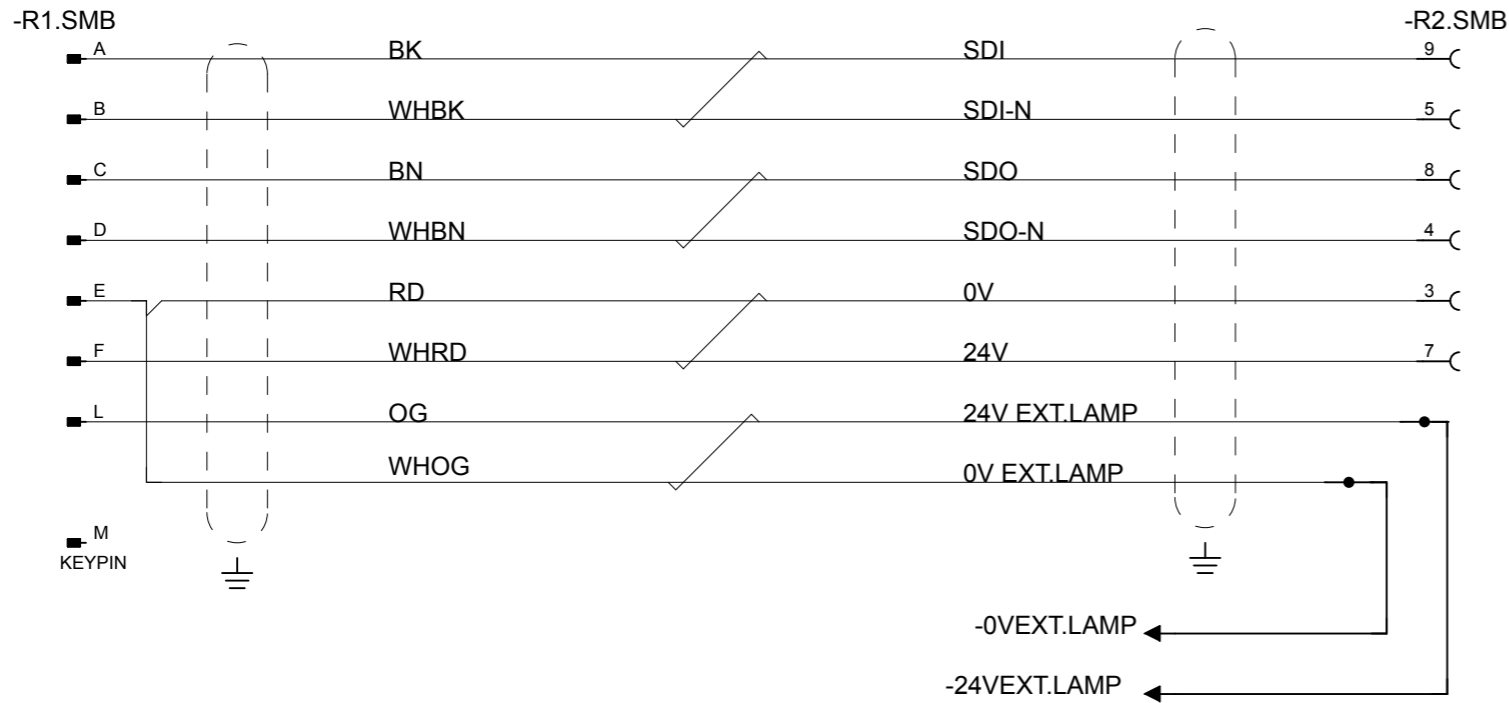
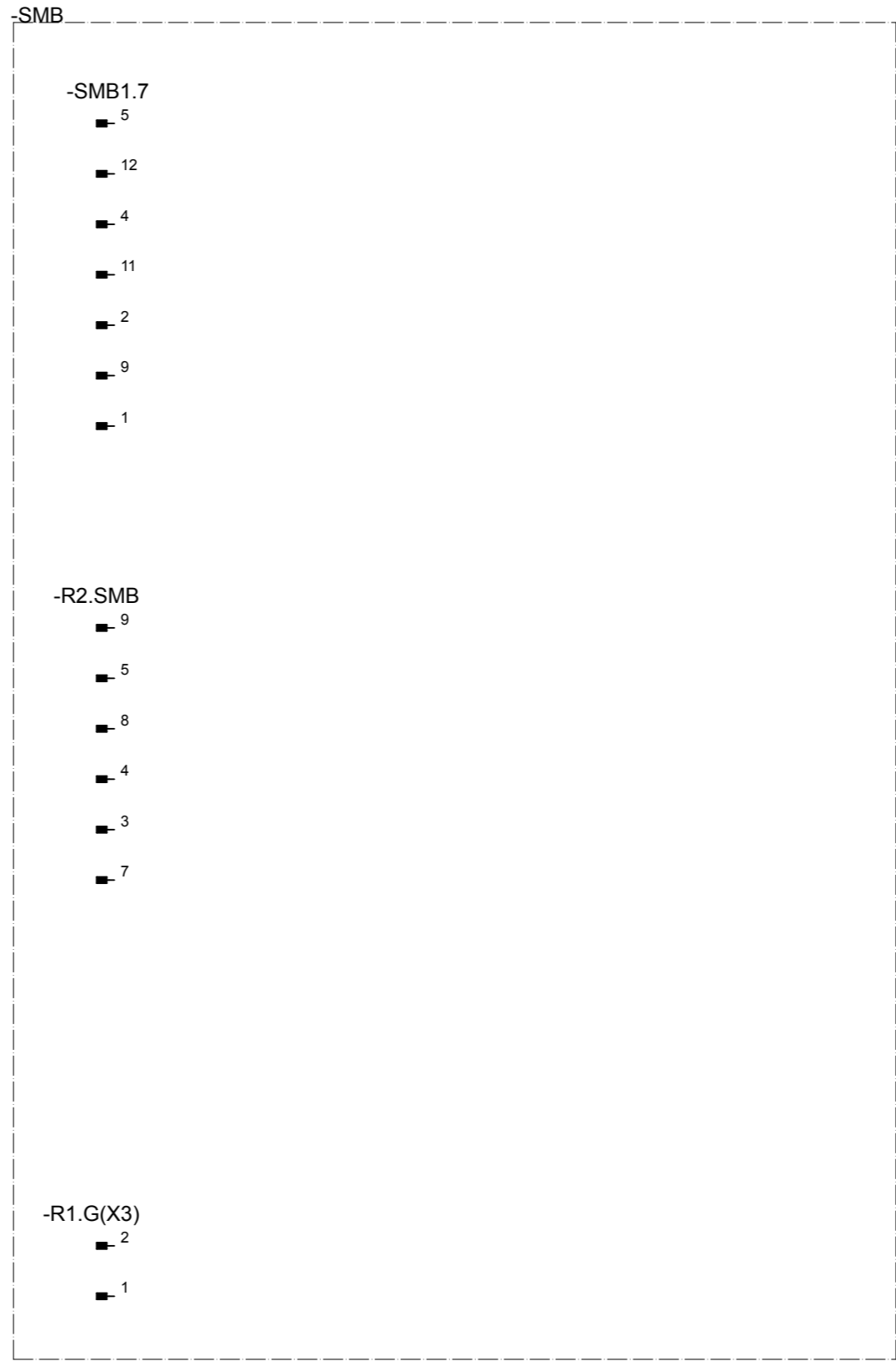
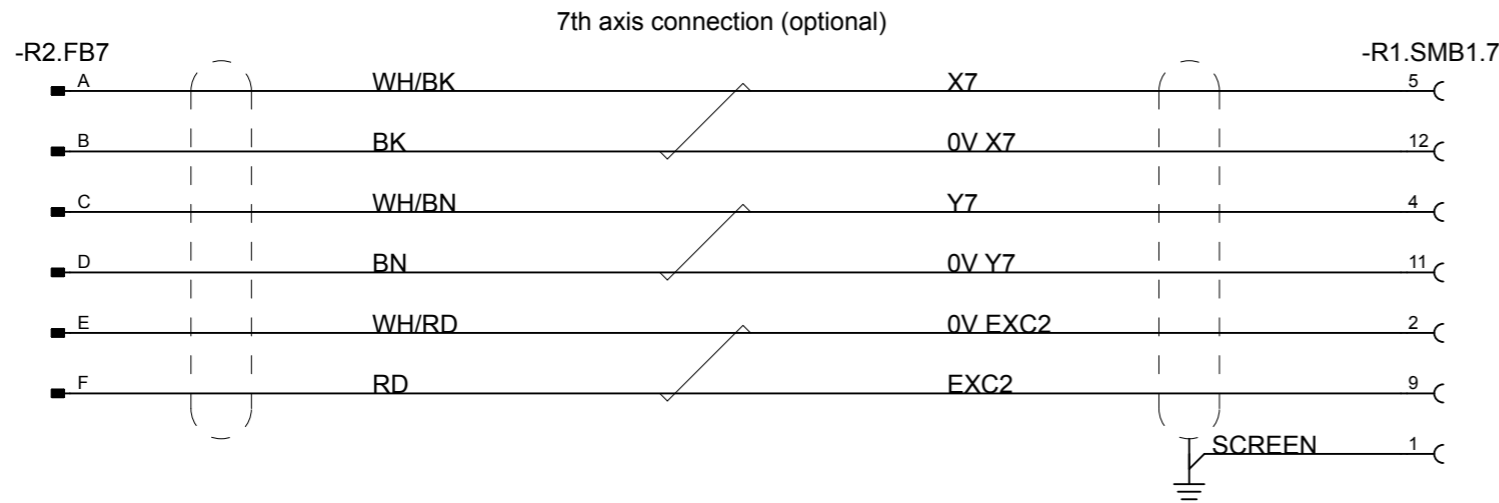

We reserve all rights in this document and in the information contained therein. Reproduction, use or disclosure to third parties without express authority is strictly forbidden. © Copyright 2003 ABB

Latest revision: ECO 77348, WI 109538
Page 10: Wire no 3 added.



Lab/Office:
DMRO SE
PRIM

IRB 6620

Serial Measuring Board

Status: 2016-01-14

APPROVED

Document no.

3HAC025090-001

Plant: = IRB6620

Location: + SMB

Sublocation: +

Rev. Ind

04

Page 20

Next +Axis1/3

Total 14

Prepared by, date: EM 151217 Approved by, date: JM 160114

We reserve all rights in this document and in the information contained therein. Reproduction, use or disclosure to third parties without express authority is strictly forbidden. © Copyright 2003 ABB

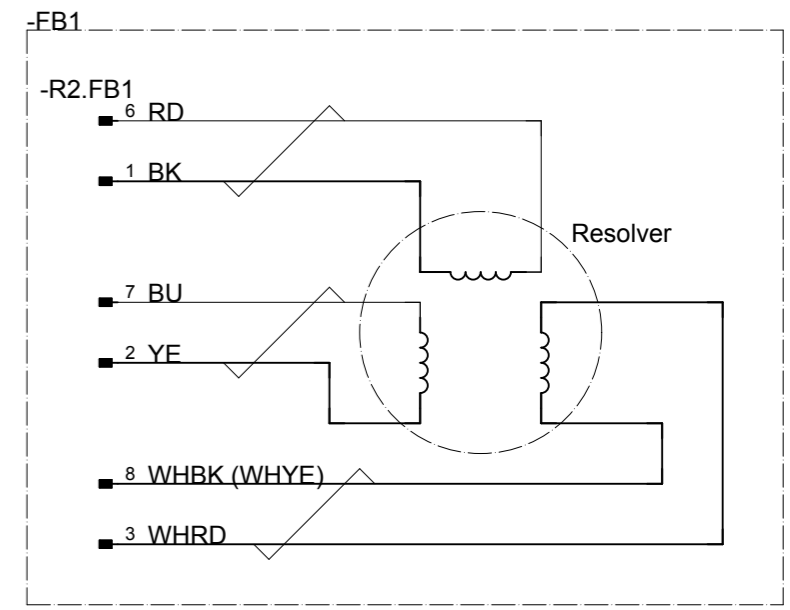
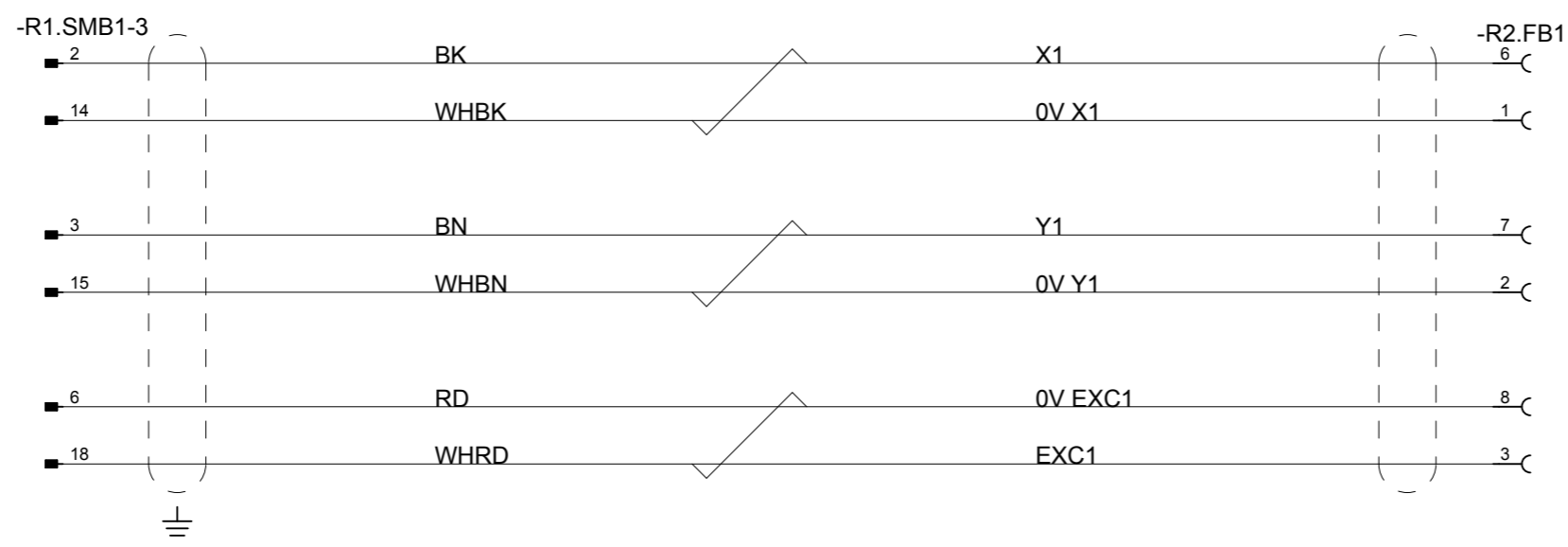
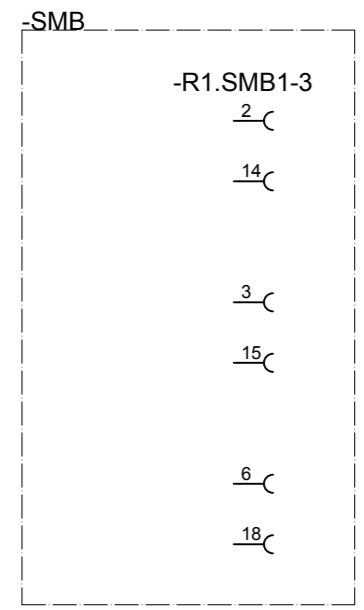
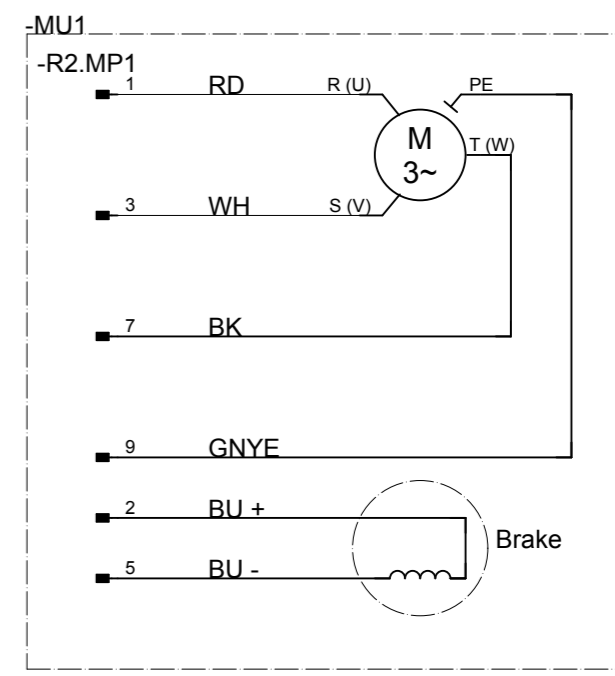
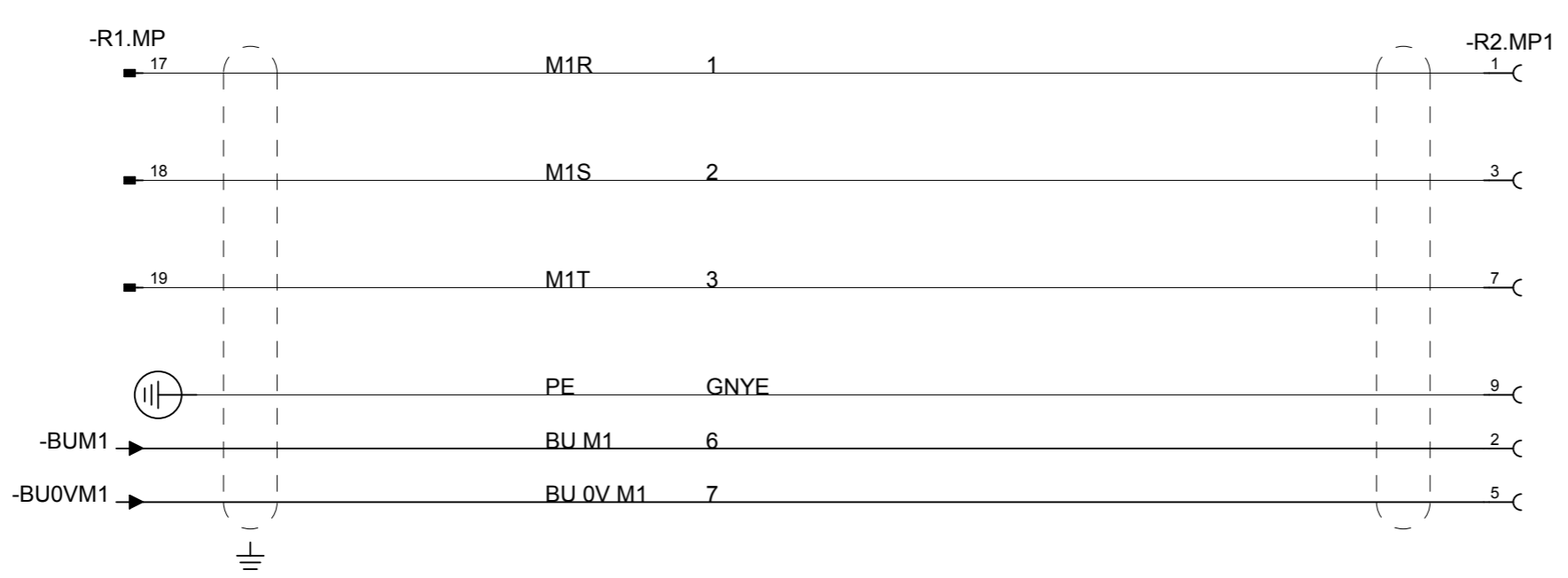

Latest revision: ECO 77348, WI 109538
Page 10: Wire no 3 added.



Lab/Office:
DMRO SE
PRIM

IRB 6620
Axis 1

Status: 2016-01-14

Plant: = IRB6620

APPROVED

Location: + Axis1

Document no. 3HAC025090-001

Sublocation: +

Rev. Ind 04

Page 30

Prepared by, date: EM 151217 Approved by, date: JM 160114

Next =IRB662
Total 14

We reserve all rights in this document and in the information contained therein. Reproduction, use or disclosure to third parties without express authority is strictly forbidden. © Copyright 2003 ABB

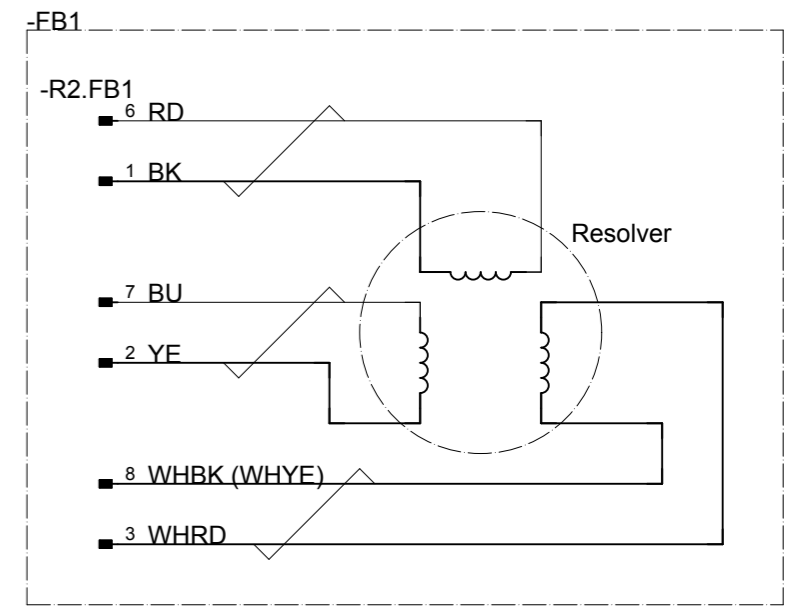
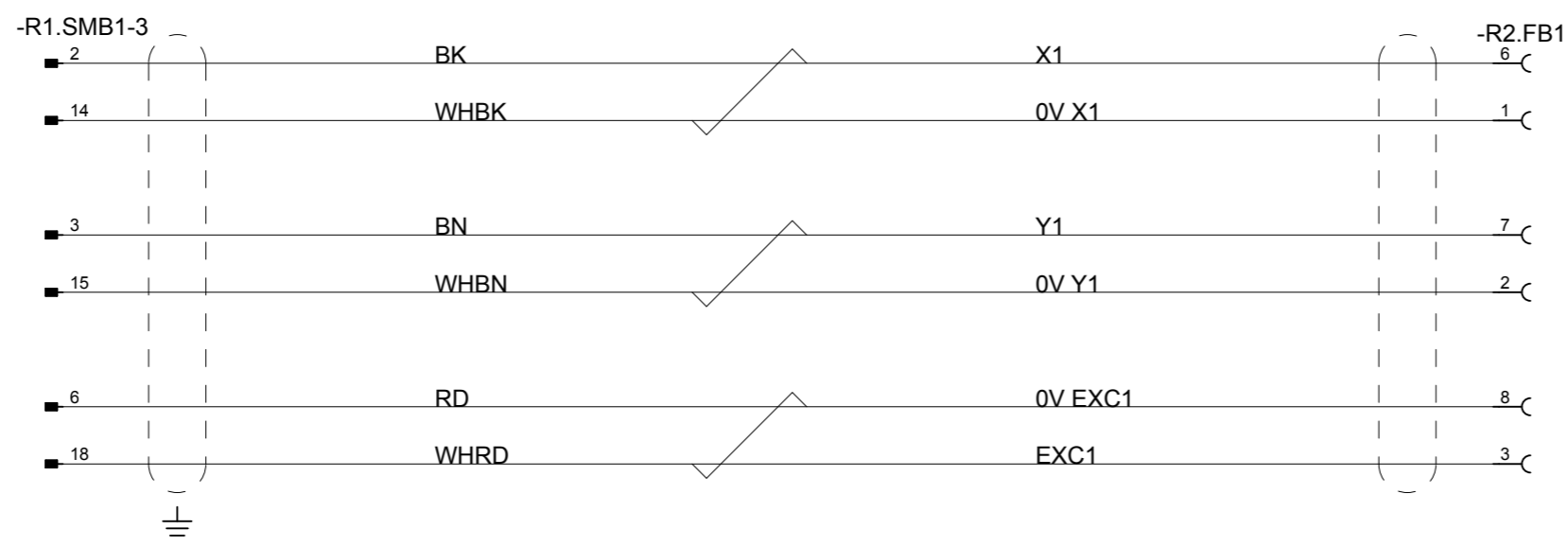
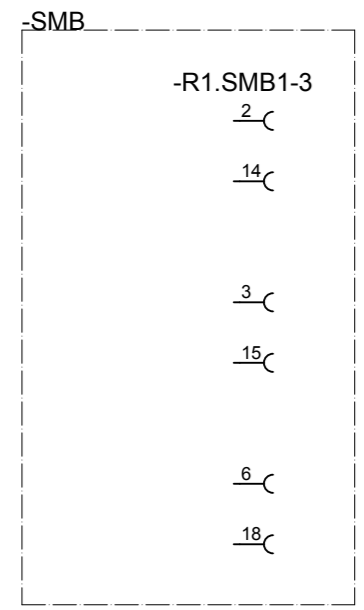
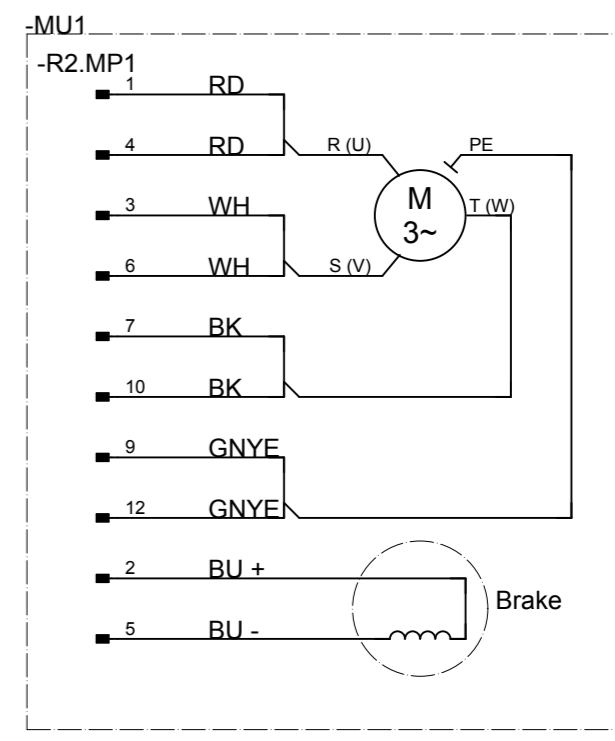
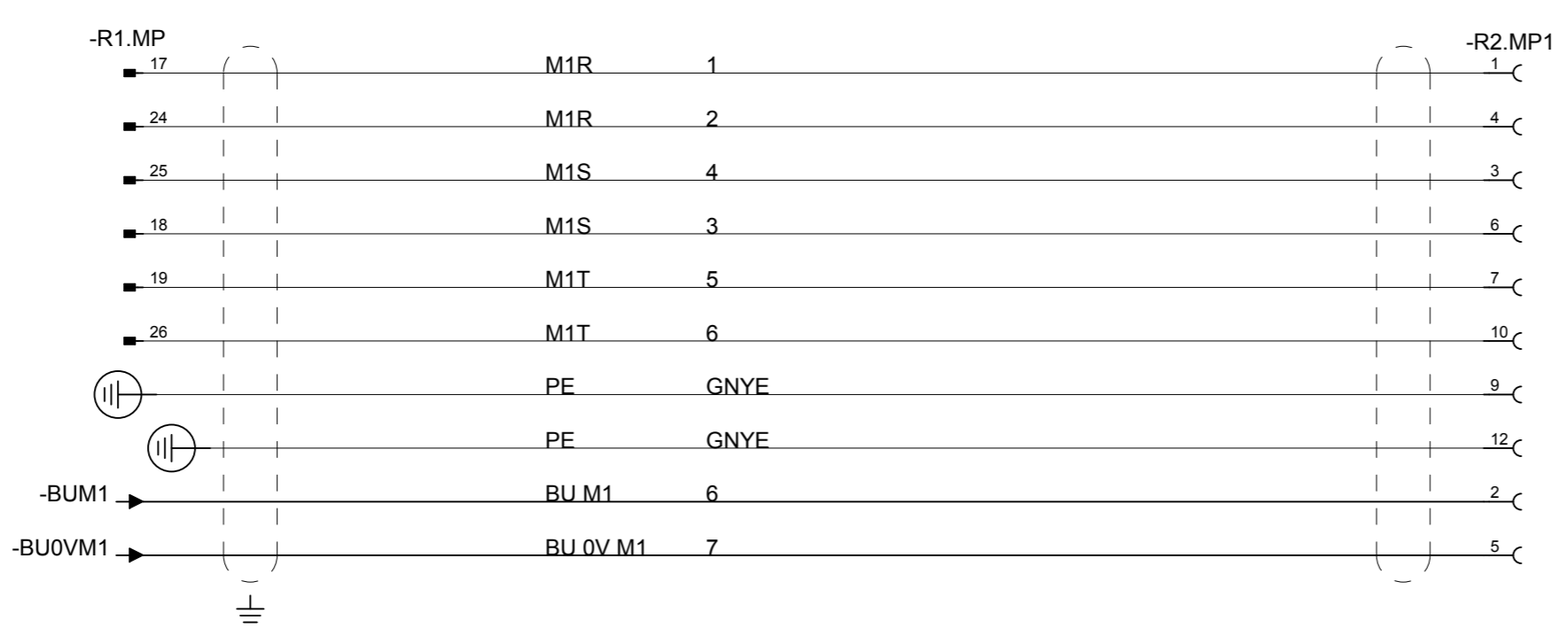

Latest revision: ECO 77348, WI 109538
Page 10: Wire no 3 added.

Prepared by, date: EM 151217 Approved by, date: JM 160114



Lab/Office:
DMRO SE
PRIM

IRB 6620
IRB 6620 LX Axis 1

Status: 2016-01-14

APPROVED

Document no.
3HAC025090-001

Plant: = IRB6620LX
Location: + Axis1
Sublocation: +

Rev. Ind
04

Page 31
Next =IRB662
Total 14

We reserve all rights in this document and in the information contained therein. Reproduction, use or disclosure to third parties without express authority is strictly forbidden. © Copyright 2003 ABB

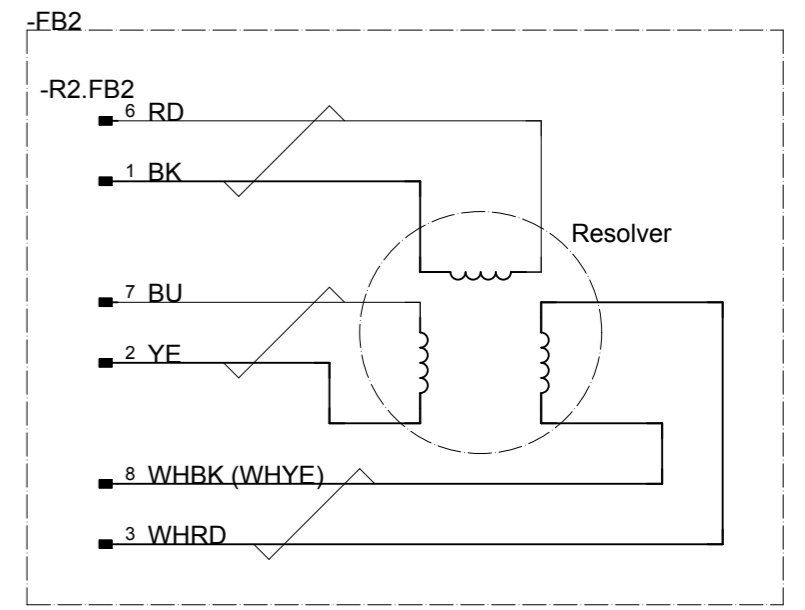
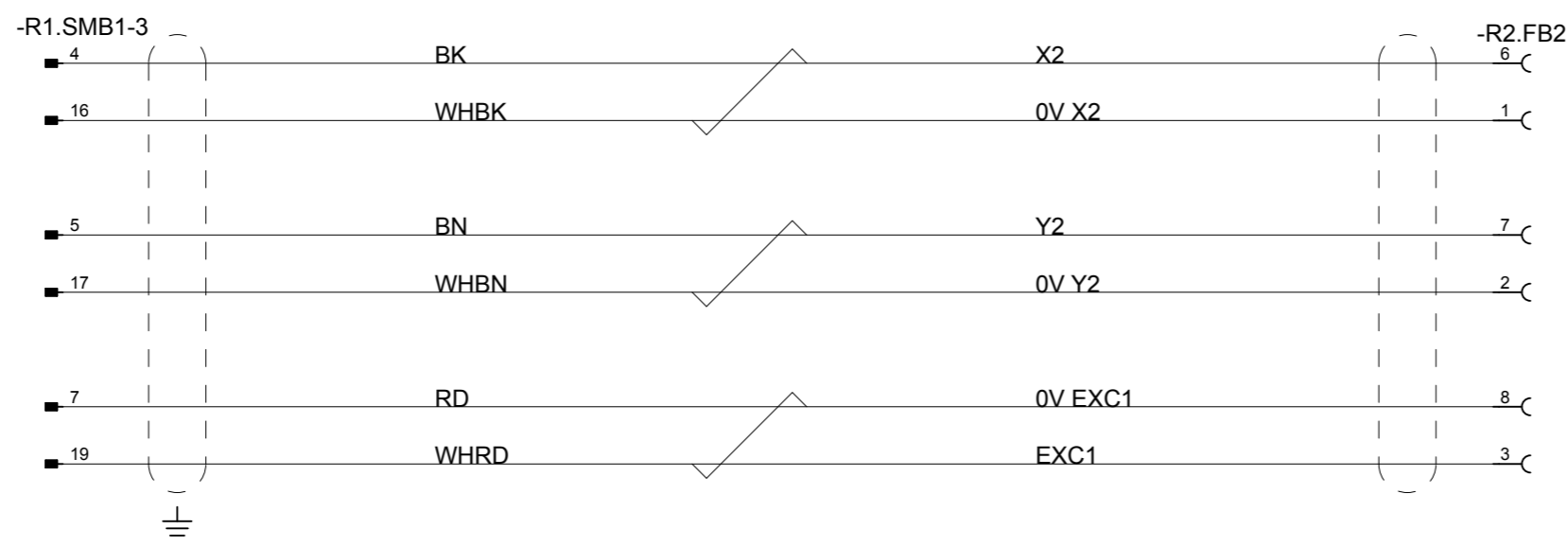
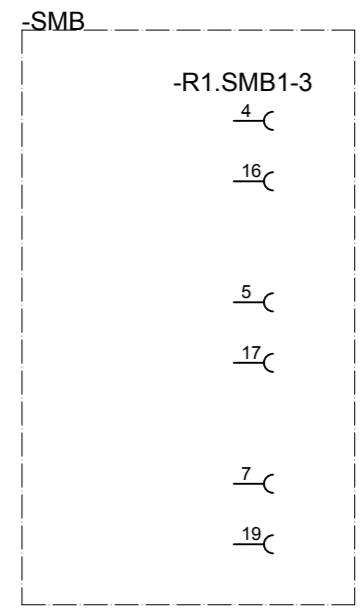
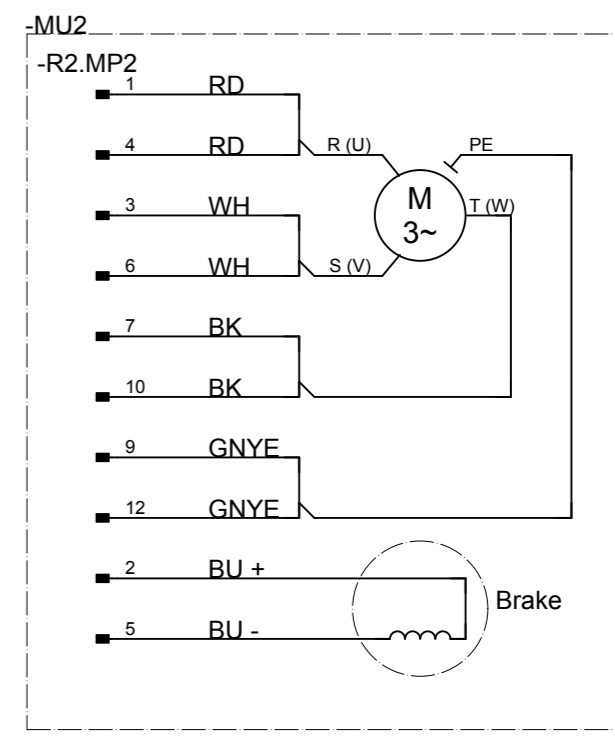
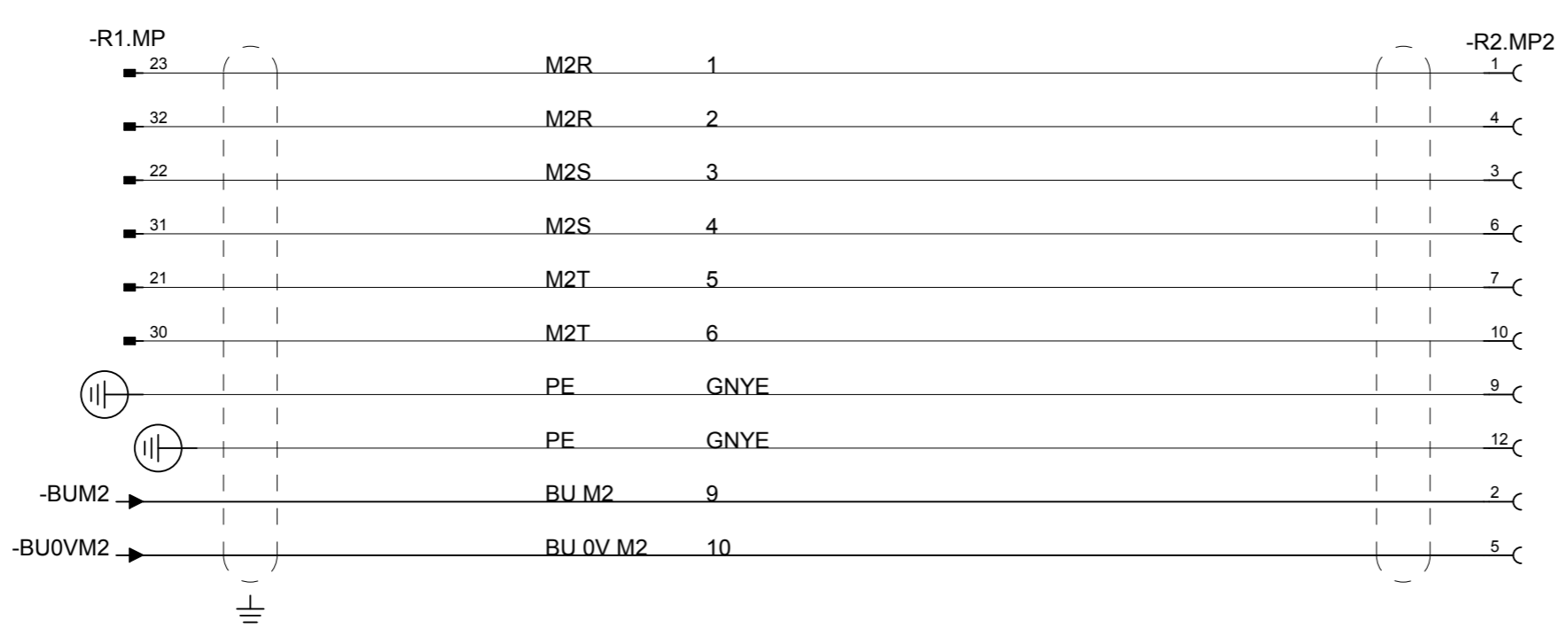

Latest revision: ECO 77348, WI 109538
Page 10: Wire no 3 added.

Prepared by, date: EM 151217 Approved by, date: JM 160114



Lab/Office:
DMRO SE
PRIM

IRB 6620
Axis 2

Status: 2016-01-14

APPROVED

Document no.
3HAC025090-001

Plant: = IRB6620

Location: + Axis2

Sublocation: +

Rev. Ind
04

Page 40

Next +Axis3/5

Total 14

We reserve all rights in this document and in the information contained therein. Reproduction, use or disclosure to third parties without express authority is strictly forbidden. © Copyright 2003 ABB

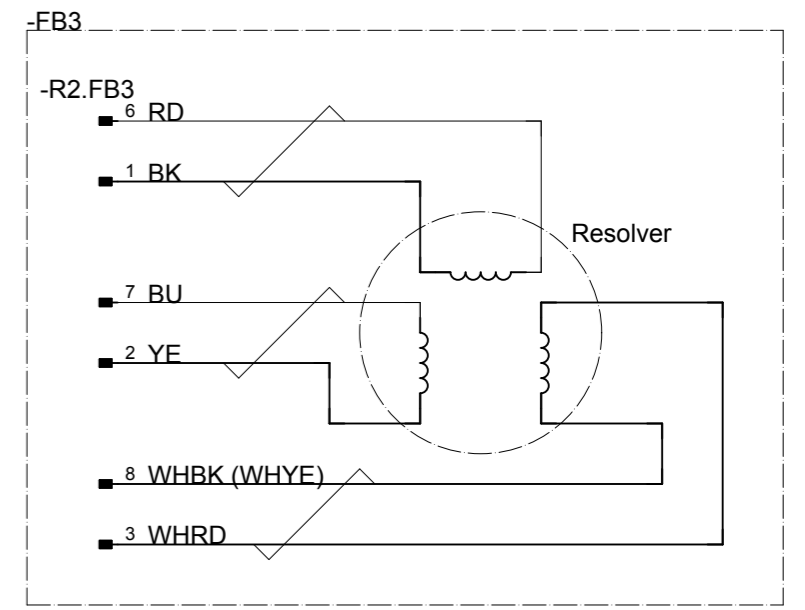
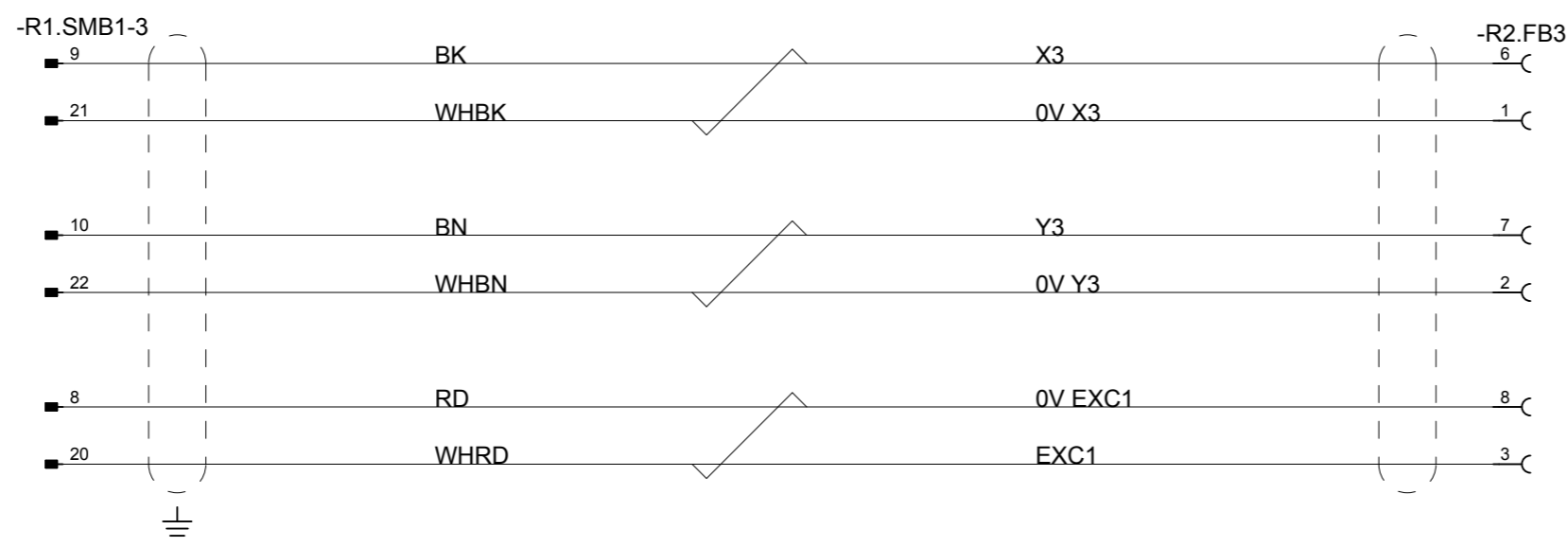
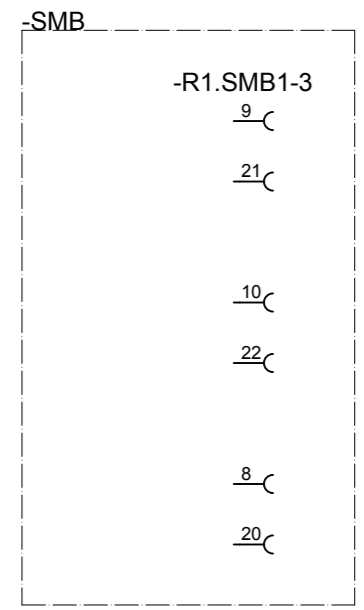
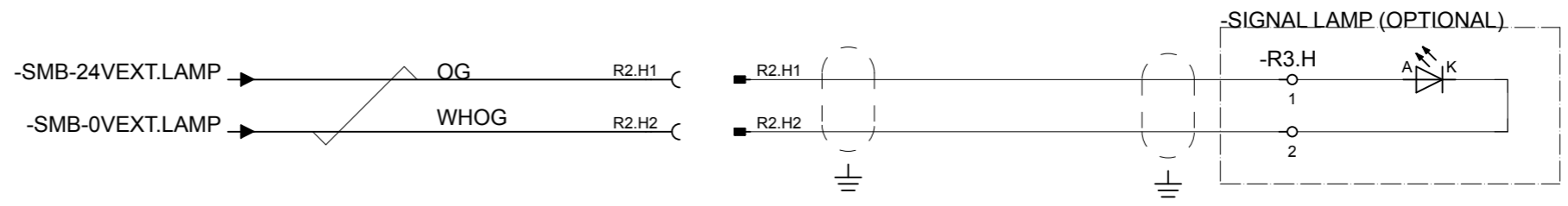
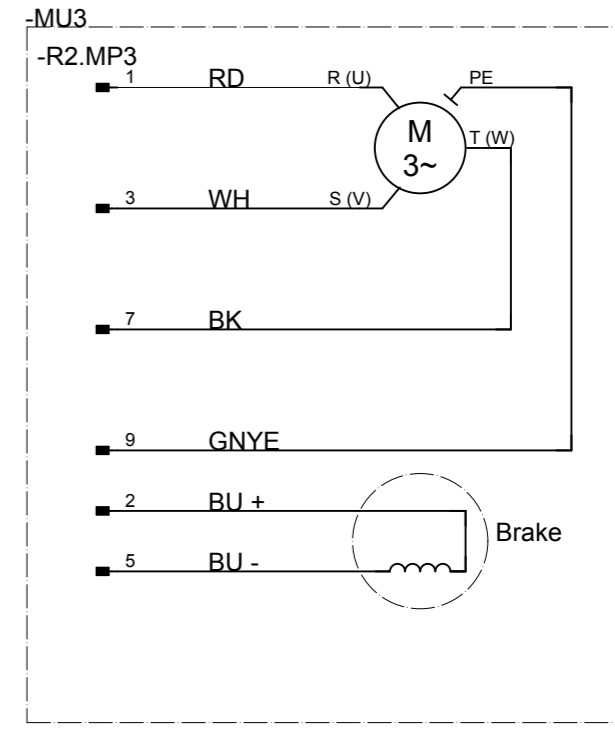
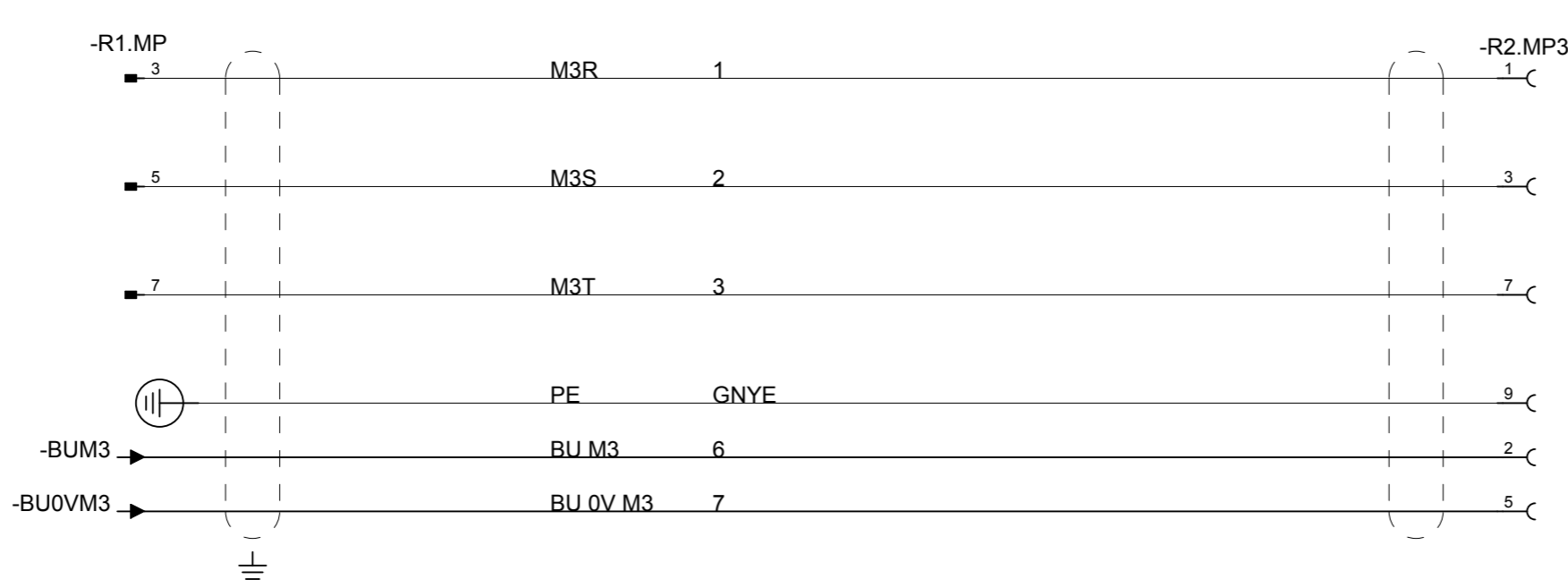

We reserve all rights in this document and in the information contained therein. Reproduction, use or disclosure to third parties without express authority is strictly forbidden. © Copyright 2003 ABB

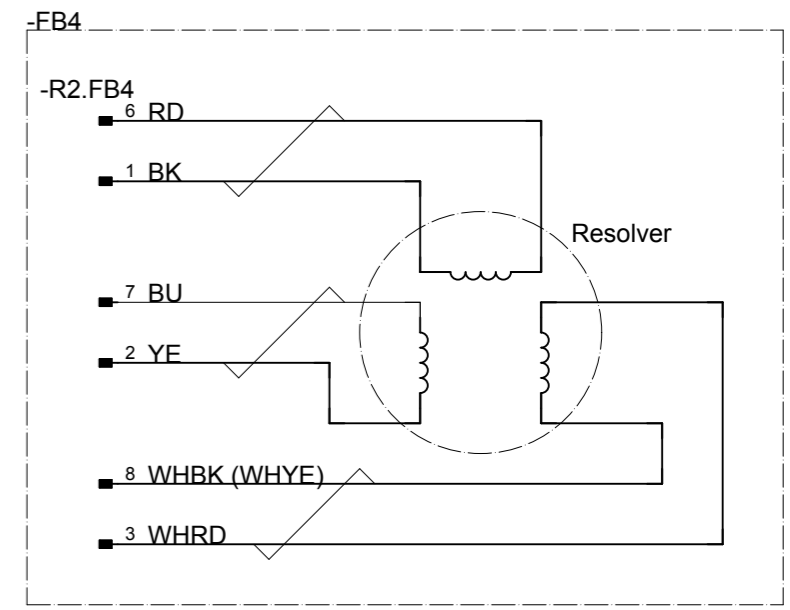
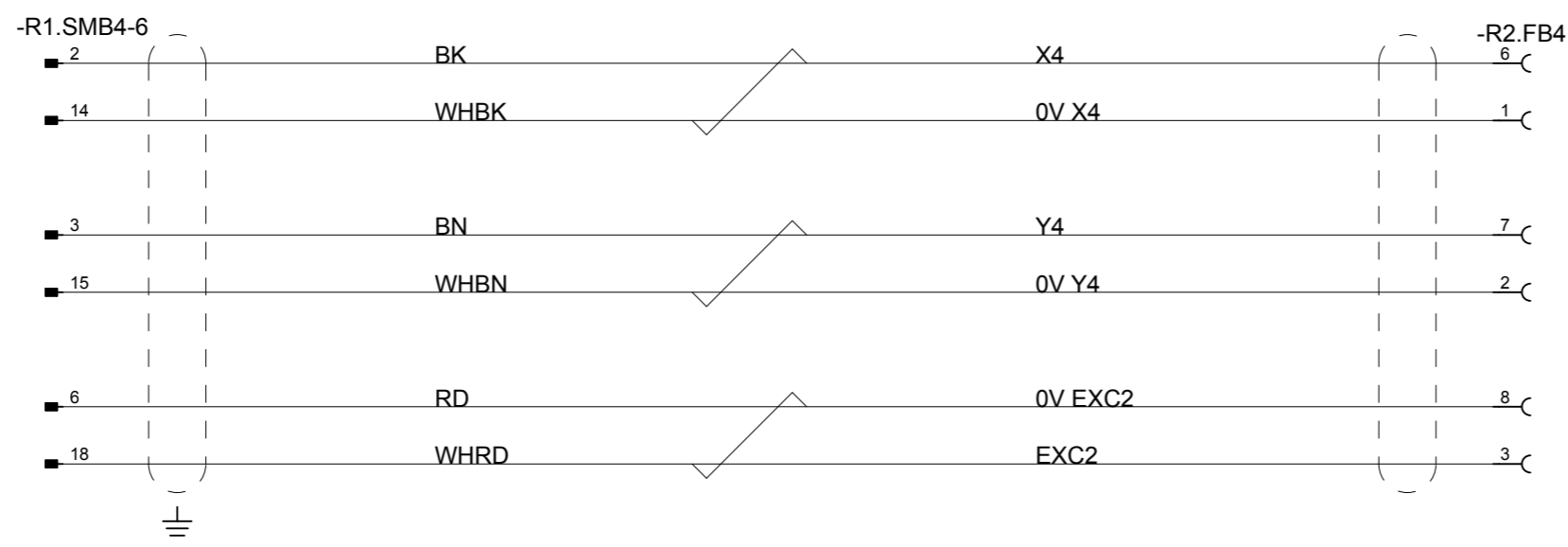
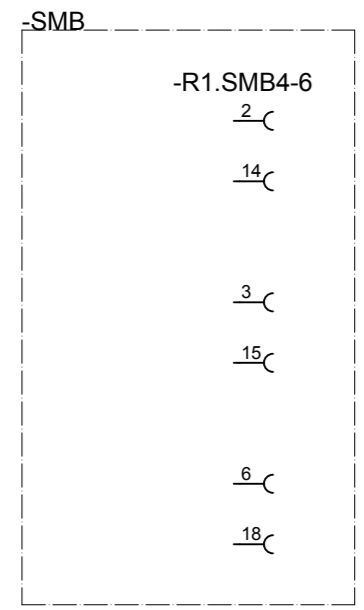
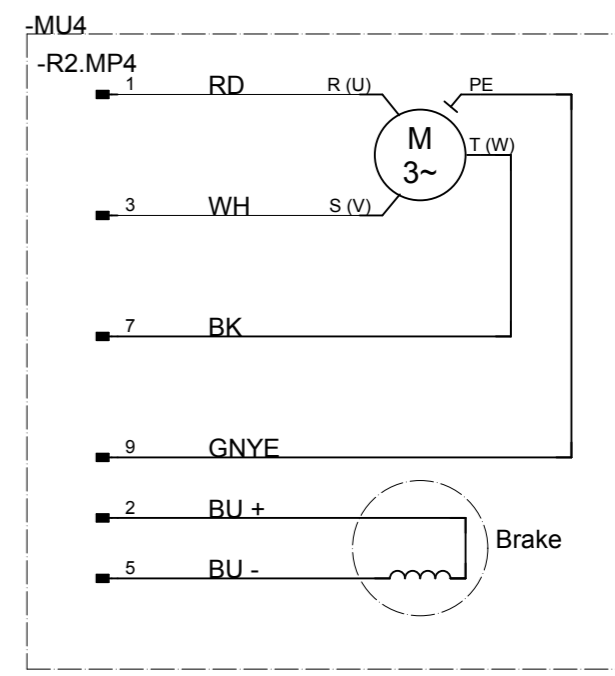
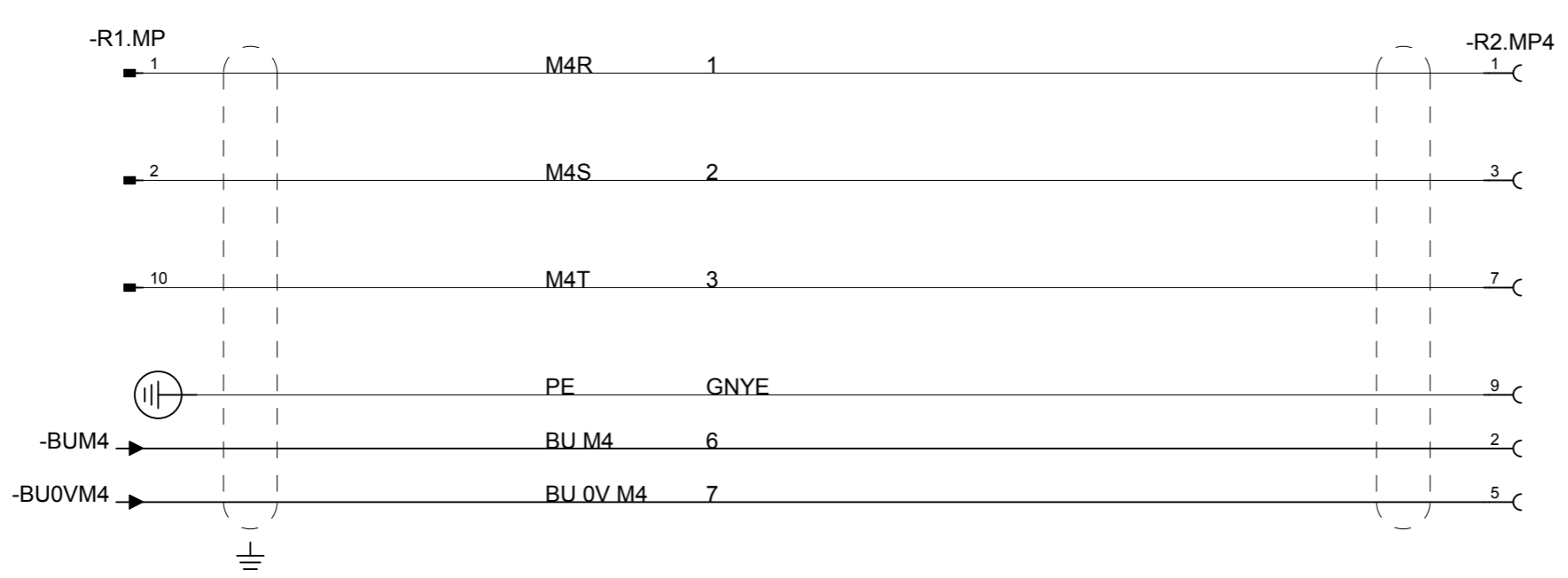

Latest revision: ECO 77348, WI 109538
Page 10: Wire no 3 added.



Lab/Office: DMRO SE PRIM
IRB 6620
Axis 4

Status: 2016-01-14
Plant: = IRB6620
Location: + Axis4
Sublocation: +

APPROVED
Document no. 3HAC025090-001

Rev. Ind 04
Page 60
Next +Axis5/7
Total 14

Prepared by, date: EM 151217 Approved by, date: JM 160114

We reserve all rights in this document and in the information contained therein. Reproduction, use or disclosure to third parties without express authority is strictly forbidden. © Copyright 2003 ABB

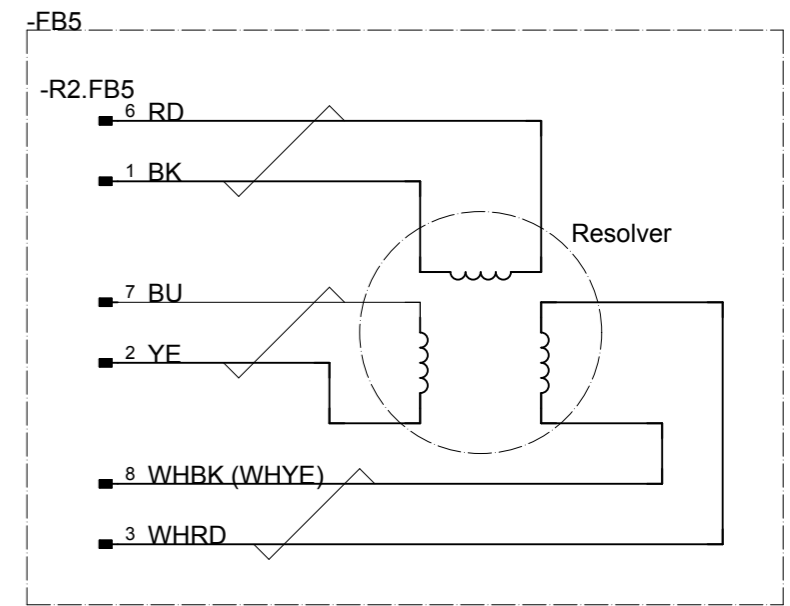
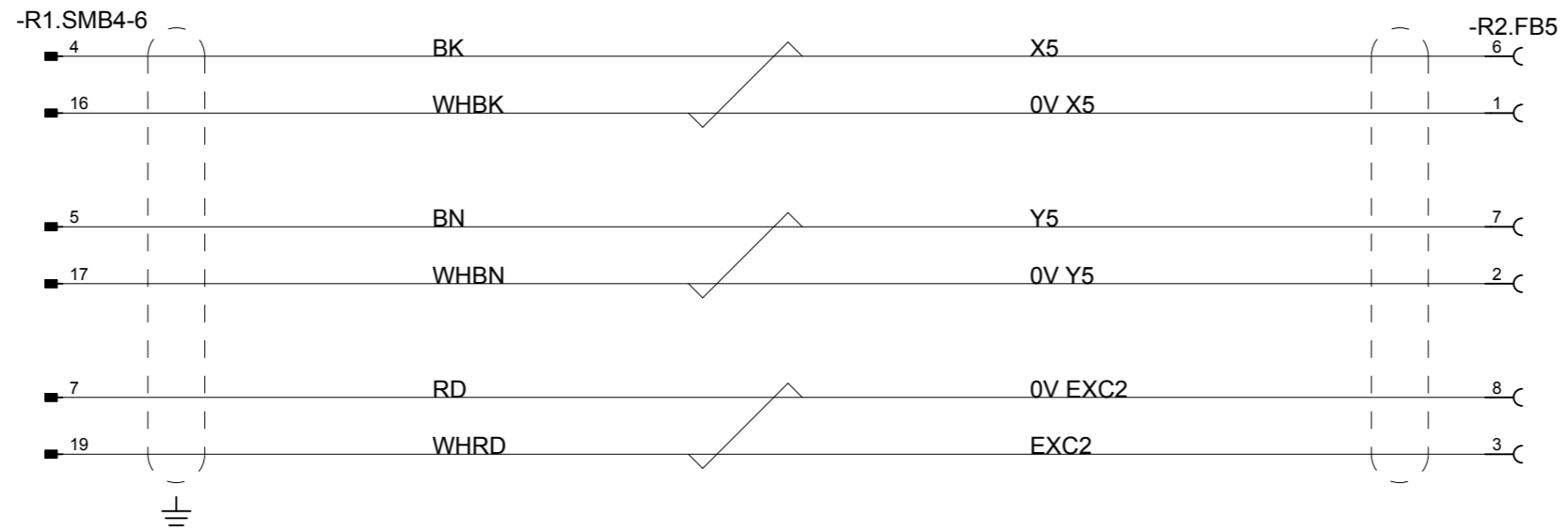
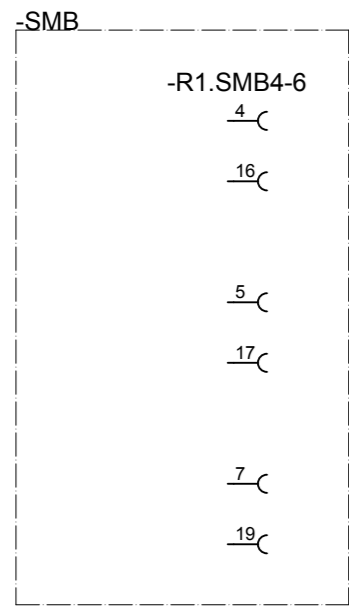
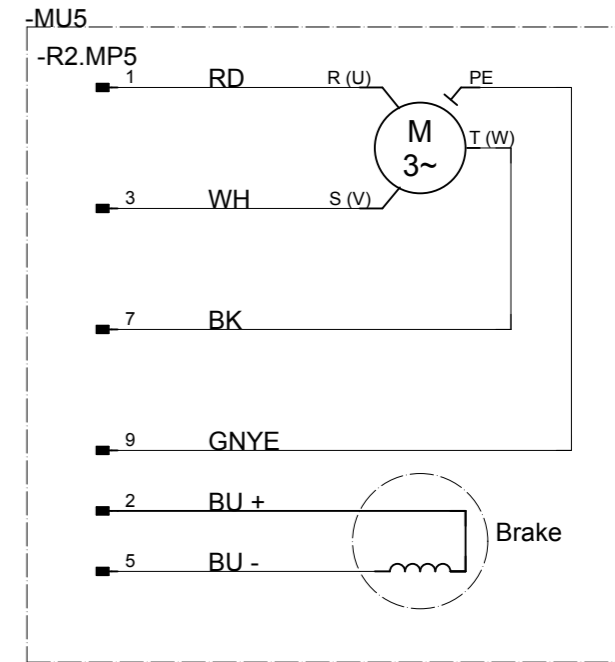
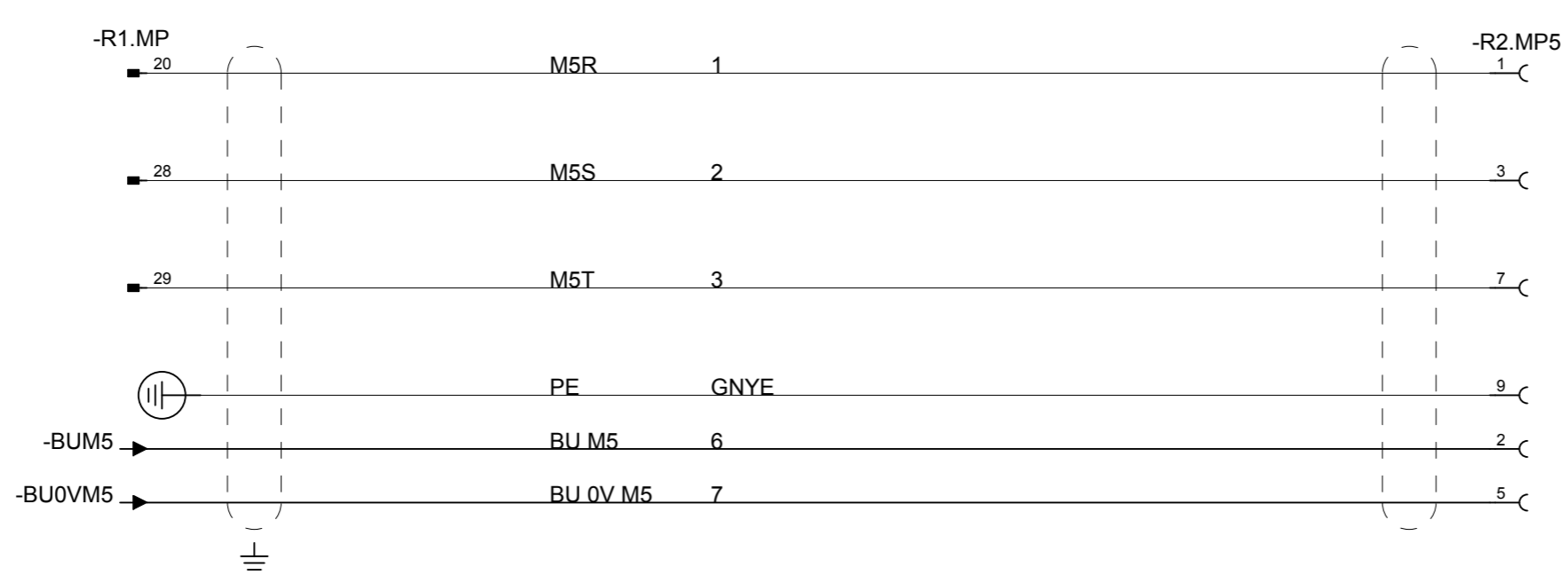

Latest revision: ECO 77348, WI 109538
Page 10: Wire no 3 added.

Prepared by, date: EM 151217 Approved by, date: JM 160114

ABB Lab/Office:
DMRO SE
PRIM

IRB 6620
Axis 5

Status: 2016-01-14
Plant: = IRB6620
Location: + Axis5
Sublocation: +

APPROVED

Document no. 3HAC025090-001

Rev. Ind **04** Page 70
Next +Axis6/8
Total 14

We reserve all rights in this document and in the information contained therein. Reproduction, use or disclosure to third parties without express authority is strictly forbidden. © Copyright 2003 ABB

